



INSTALLATION INSTRUCTIONS

PWM POWERPACK FAN ASSEMBLY

PART # 66825, 66826, 66830, 66831, 66833, 66835,
66836, 66837, 66838, 66842 & 66927

Please read these instructions completely before beginning installation

FAN SHROUD ASSEMBLY KIT CONTENTS

QTY.	DESCRIPTION	QTY.	DESCRIPTION
1	Dual Fan Shroud Assembly	1	Rubber Fan Shroud Seal
1	PWM Fan Controller Kit	16	1/4-20 x 3/4" Hex Bolts
4	Angle Brackets	16	1/4-20 Lock Nuts
		40	1/4" Flat Washers

TOOLS NEEDED

Drill	Standard Screw Driver (1/8" wide blade)
5/32" Drill Bit	Wire Stripper
Multimeter / Test Light	Wire Crimping Tool
5/16" Nut Driver	
7/16" Open End Wrench	
7/16" Socket & Ratchet	

IMPORTANT

This fan assembly is designed for PULLER APPLICATIONS ONLY Engine side of radiator. (See Diagram #1)

MOUNTING OPTIONS

Diagram #1

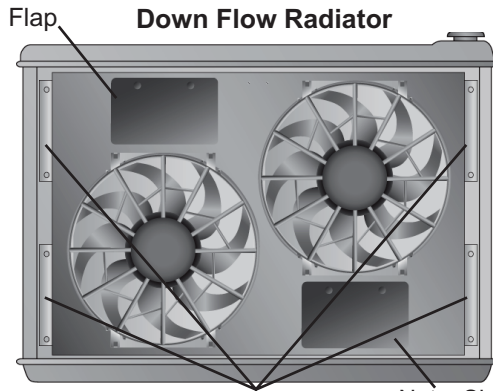

MOUNTING OPTIONS

Cross Flow Radiator

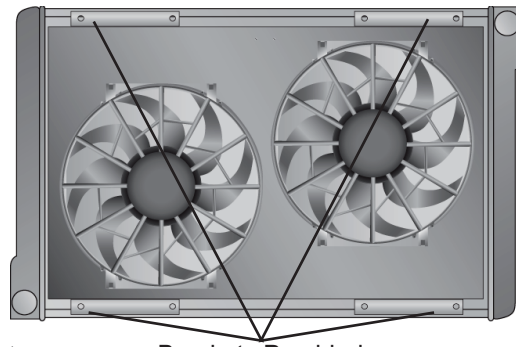

Brackets Provided Note: Shrouds with vents must open at bottom

Brackets Provided

Shroud should be mounted tight against radiator to minimize air leaks that would reduce efficiency.

Diagram #2

Option 1 Flush Mount

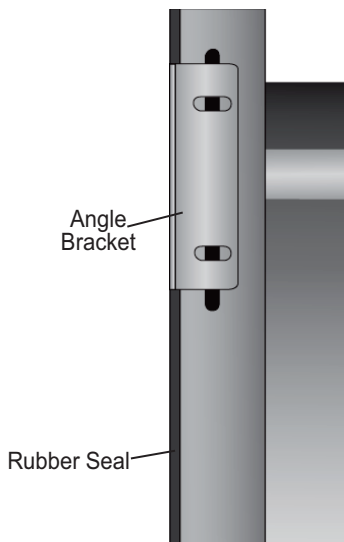

Option 2 Recessed Mount

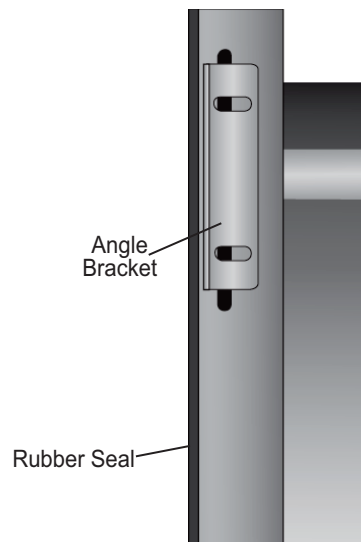

Adjustment Range

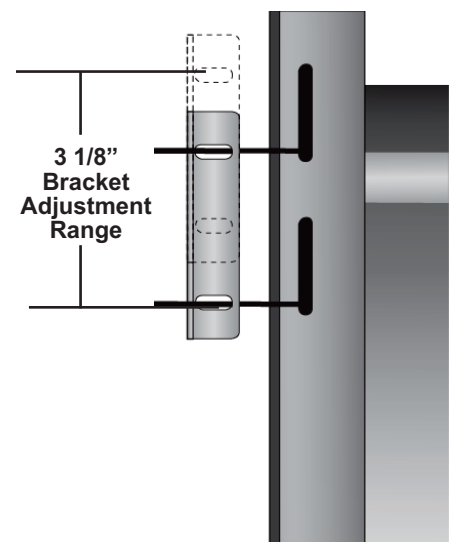

INSTALLATION OF ELECTRIC FAN ASSEMBLY TO RADIATOR

Warning: Temperature Probe must be installed Prior to Shroud Installation. See Thermostat Probe Installation Section.

Before installing shroud Reference Diagrams # 1 & 2 on page 1 to decide how the Assembly should be mounted to radiator.

1. Using a table or workbench, lay the Electric Fan Assembly on a flat surface.
2. Take the supplied Rubber Fan Shroud Seal and install it onto the bottom edge of the Fan Shroud Assembly. (See Diagram #3)
3. Cut off any excess Rubber.
4. Identify the four Angle Brackets, 1/4-20 x 3/4" Hex Bolts, 1/4" Flat Washers & 1/4-20 Lock Nuts.
5. Attach the Angle Brackets to the Shroud using two bolts per bracket. (See Diagram #4)

Note: In some applications where the radiator flange is not right up against the fan shroud, longer bolts can be used to space the Angle Brackets. (See Diagram #5) Hardware not included.

6. Position the Electric Fan Assembly against the radiator in the desired location.
7. Using the remaining 1/4-20 x 3/4" Hex Bolts, 1/4" Flat Washers & 1/4-20 Lock Nuts, attach the Electric Fan Shroud Assembly to the radiator. (See Diagram #4)

Diagram #3

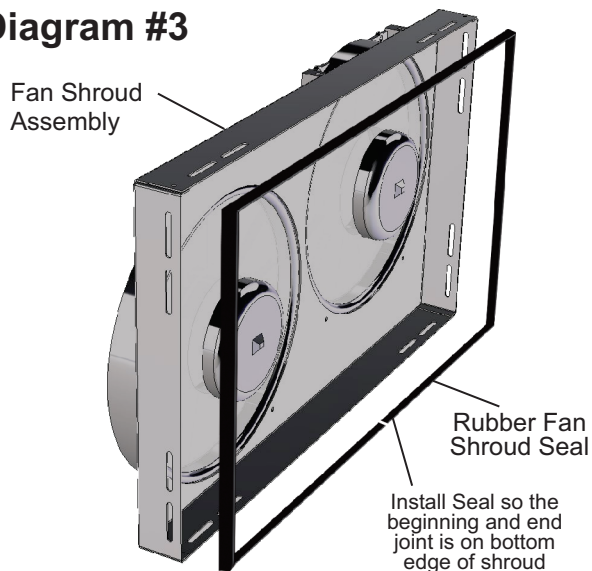

Diagram #4

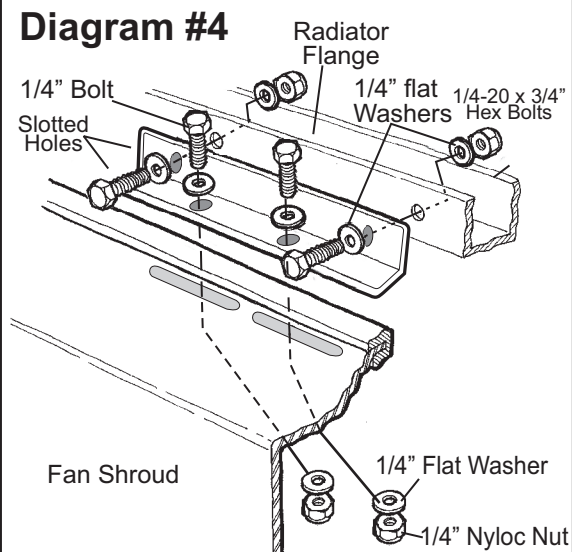
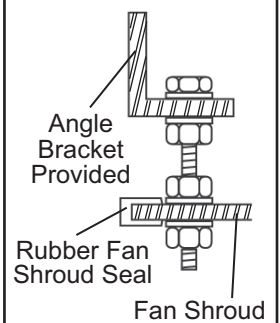

Diagram #5

OPTIONAL MOUNTING





INSTALLATION INSTRUCTIONS PWM ELECTRIC FAN CONTROLLER PART # 16797



Please read these instructions completely before beginning installation

KIT CONTENTS

QTY.	DESCRIPTION
1	PWM Fan Controller
1	Sensor (Pre-wired to controller)
1	50 Amp Circuit Breaker
6	#10 Sheet Metal Screw
1	2ft 10 AWG Red Wire
1	Yellow Butt Connector
2	Yellow 5/16" Ring Terminal
2	Yellow #10 Ring Terminal
2	Blue Wire Tap Connector
4	4" Wire Ties

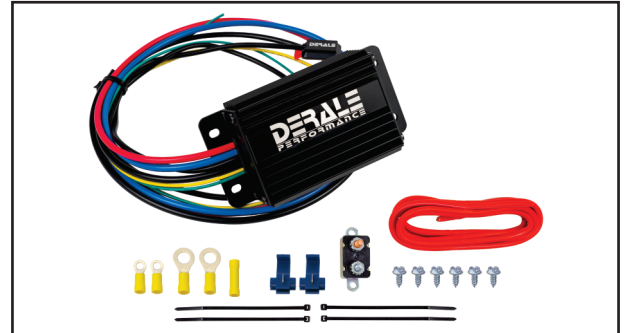

IMPORTANT NOTES

This fan controller has been completely quality control tested prior to final packaging.

MAXIMUM CAPACITY: 70 AMPS

This controller will operate multiple fans with a combined maximum amperage up to 70 amps. On dual fan applications, it is important to know your fan(s) amp draw before installing, if fan(s) exceed 70 amps, all warranty will be void.

AUTO RESETTING CIRCUIT BREAKER

The fan controller utilizes a 50 amp auto resetting circuit breaker to protect the fan(s) and controller circuit. In the event of an electrical issue, the breaker will "trip" and open the connection between the battery and the controller. The circuit breaker will automatically reset once the issue has been corrected. If installing fan(s) exceeding 50 amps in total you must use a fuse or circuit breaker suitable for your systems amp draw.

MAIN POWER CONNECTIONS

The positive and negative wires feeding the fan controller MUST be connected directly to the vehicles battery.

This is very important because the controller requires a clean signal, do not connect directly to the fuse panel, starter or the alternator.

VEHICLES BATTERY LOCATION

If the vehicles battery is located more than 5 feet from the fan controller, the signal could encounter some interference or noise, which causes a dirty signal. In some cases, a larger 6 gauge wire may be required. Please contact our technical support team for more information. (323) 266-3850 or techsupport@usmotorworks.com

TEMP SENSOR

This unit is equipped with a newly released aluminum temp sensor that reacts 50% quicker than previous models. It uses 3M double stick tape to adhere right to the radiator tank, therefore getting a very accurate temperature reading. The surface preparation is critical; surface must be absolutely free of dirt, oil, peeling paint or any contaminants to ensure a proper bond.

Important: The ideal application temperature range is 70°F to 100°F (21°C to 38°C). The minimum suggested application temperature is 50°F (10°C). At 70°F approximately 50% of the ultimate bond strength will be achieved after 20 minutes, 90% after 24 hours and 100% after 72 hours.

OVERRIDE CIRCUIT

The fan controller has an override circuit (Green Wire) available that when activated, will ramp up the electric fans to 60% running speed. As the engine temperature increases the fans will increase accordingly.

WIRE CONNECTIONS

Crimp connections are critical to the function of this controller, please ensure that all connections are made using quality crimpers. After each crimp has been completed, tug wires, there should be no movement within the connector. Ground connectors are crucial. If grounding to chassis we do not recommend using self tapping screws as they tend to loosen over time.

COOL DOWN FUNCTION

This PWM fan controller is designed with a cool down function that will allow the electric fan(s) to run for 20 seconds after the vehicle has been turned off.

FAN CONTROLLER INSTALLATION

1. Choose a convenient location, preferably along the vehicles core support near the battery. Take in to consideration sensor placement & wire routing requirements. Avoid mounting near HOT engine components or a location that would be in direct contact with any road debris.
2. Using the fan controller as a template, mark and drill four 5/32" holes in the proper location.
3. Using four #10 sheet metal screws supplied, secure the unit in place.

CIRCUIT BREAKER MOUNTING

1. Choose a convenient location for the circuit breaker that is between the fan controller and the battery.
2. Using the circuit breaker as a template, mark and drill two 5/32" holes in the proper locations.
3. Using the remaining two #10 sheet metal screws supplied, secure the circuit breaker in place.

SENSOR INSTALLATION

- 1) Determine the desired mounting location of the sensor, somewhere on the radiator near the water inlet. (See Diagram #1)
- 2) Route the path of the sensor wires from the controller to the radiator. If necessary, you can lengthen or shorten the wires using an automotive grade 22-gauge wire.
- 3) Once you have routed the wires and have the sensor location chosen, clean and dry the area with alcohol, making sure there is no left over residue.
- 4) Remove the Red 3M backing paper from the sensor and install the sensor in the desired location, applying firm pressure for at least 15 seconds.

NOTE: This unit uses 3M double stick tape to adhere right to the radiator tank, therefore getting a very accurate temperature reading. The surface preparation is critical; surface must be absolutely free of dirt, oil, peeling paint or any contaminants to ensure a proper bond.

The Ideal application temperature range is 70°F to 100°F (21°C to 38°C). The Minimum suggested application temperature is 50°F (10°C). At 70°F approximately 50% of ultimate bond strength will be achieved after 20 minutes, 90% after 24 hours and 100% after 72 hours.

WIRING

Before starting, disconnect the negative (-) cable on the vehicles battery.

Using the electrical connectors and wire ties provided, follow the instructions below.

WARNING: The positive and negative wires feeding the controller MUST be connected directly to the vehicles battery.

This is very important because the controller requires a clean signal, do not connect directly to the fuse panel, starter or the alternator. **Improper installation will void the warranty.**

1. Using a yellow 5/16" ring terminal & 10 AWG Red Wire supplied, connect one end of the Red Wire to the vehicles positive (+) terminal on the battery.
2. Route the 10 AWG Red Wire now connected to the battery to the circuit breaker previously installed and cut the wire to the appropriate length.
3. Using a yellow #10 ring terminal, connect the 10 AWG Red Wire to the "BAT" (Copper Colored) terminal on the circuit breaker.
4. Using a yellow #10 ring terminal, connect the auxiliary side "AUX" (Silver Colored) of the circuit breaker to the length of 10 AWG Red Wire of the controller wire harness.
5. Using a Yellow Butt Connector connect the Blue Wire from the controllers wire harness to the Positive Wire(s) of the Electric Fan(s) being controlled.
6. Using the 5/16 Yellow Ring Terminal connect the 10 AWG Black Wire from the controllers wire harness direct to the batteries negative terminal.
7. Connect the electric fan(s) being controlled direct to the negative stud or a good chassis ground. Use the shortest wire route possible.
8. Using a Blue Wire Tap connector attach the Yellow Wire to a Positive (+) switched ignition source.

Diagram #1

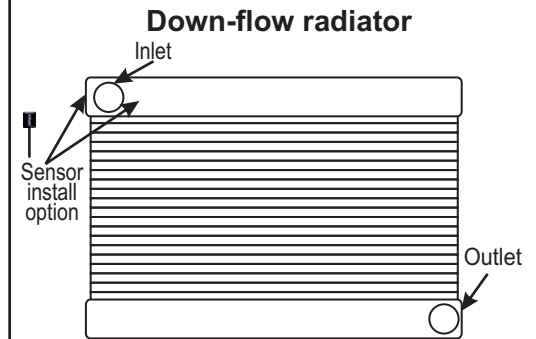
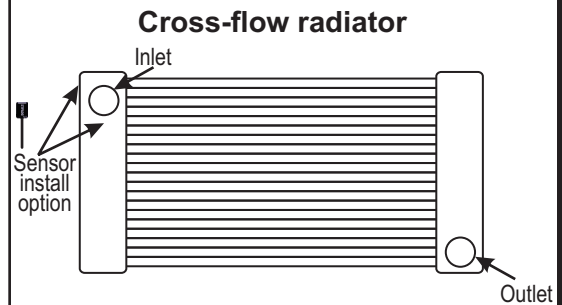

Green Wire: Override Circuit (Optional)

The green wire is designed to work in two different configurations. When used, this will allow the electric fan(s) to be turned on regardless of the temperature of the cooling system. The fan speed will quickly ramp up to 60% and will operate between 60 and 100% as temperature increases and decreases. Connect the Green wire to either option A or B below.

Note: Use of the Override is optional and not required for the PWM controller to work properly.

- A. A/C Override - Using the blue wire tap connector provided, attach the green wire to a positive (+) 12V output on the A/C High Pressure Switch.
- B. Manual Switch Override - Attach the green wire to the 12V output on the manual switch (not provided.)

VEHICLE TESTING

1. Before you start the vehicle, make sure all wires are safely zip tied and away from any moving parts.
2. Start the vehicle.
3. If the manual override function is being used, turn on the A/C or manual switch. Electric fan(s) will ramp up to 60%.
4. Turn off the manual override or A/C function and allow the engine to warm up, fans will ramp up slowly as the vehicle warms up.

ADJUSTING THE TURN-ON TEMPERATURE

The PWM Controller is factory set at approximately 180°F. Therefore Fans will adjust speed to maintain 180°F fluid temperature. Using the adjustment screw on side of the controller the temperature can be adjusted to maintain fluid temperatures from 130°F - 230°F. Follow the directions below to make adjustments to the temperature.

1. Remove the rubber plug from the side of the fan controller
2. Using a 1/8" blade screwdriver, follow the instructions below:

If your engine is running too cool: Turn the adjustment screw **CLOCKWISE** in increments of 2 FULL turns, then test before repeating.

If your engine is running too hot: Turn the adjustment screw **COUNTER-CLOCKWISE** in increments of 2 FULL turns, then test before repeating.

Diagram #2

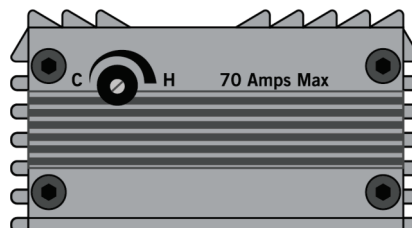

WIRE COLOR QUICK REFERENCE GUIDE

Red Wire: Battery Positive (+)

Black Wire: Battery Negative (-)

Blue Wire: Fan Positive (-)

Yellow Wire: Positive (+) Switched Ignition Source

Green Wire: A/C Override or Manual Override 12V Positive (+)

(Page 5)



Please direct all technical questions to our Derale tech line at (323) 266-3850



Warning: Installation of accessories should only be undertaken by those with mechanical knowledge and are familiar with working on vehicles. Always use eye protection (goggles, safety glasses or shield). Park the vehicle in a well lit area, on level ground and apply the parking brake. Only work on a cold vehicle that has been sitting overnight, failure to do so will result in severe burns and injury. Before starting the vehicle, make sure no tools or any other items are left under hood that could interfere with or be drawn into moving parts of the engine. Failure to follow instructions can lead to severe damage and personal injury.

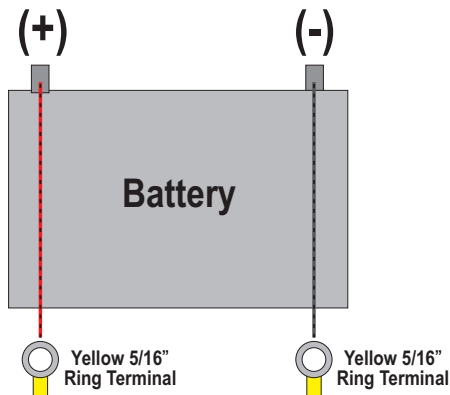

IMPORTANT
Positive and Negative Controller wires must be connected to the vehicles battery

PWM Fan Controller

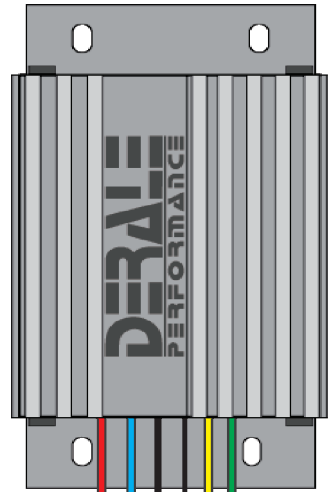

Yellow Wire
Positive (+) switched ignition source

Green Wire
Optional Override Circuit 12 (+)

Black Wire

Red Wire

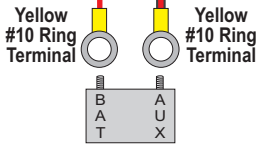

Circuit Breaker

Sensor Wire

Radiator (Sensor Placement)

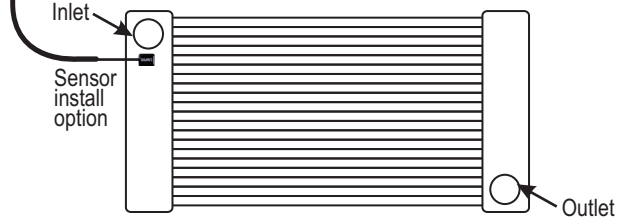

Blue Wire

Connect the Blue Wire from the wire harness to the Positive (+) Wire(s) of the Electric Fan(s).

Fan(s) (-)
Connect the Negative (-) wires on the electric fan(s) to a good chassis ground.

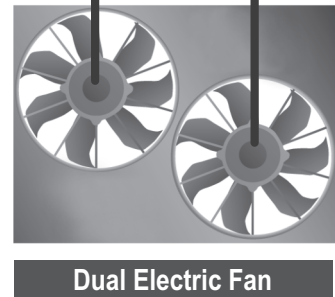
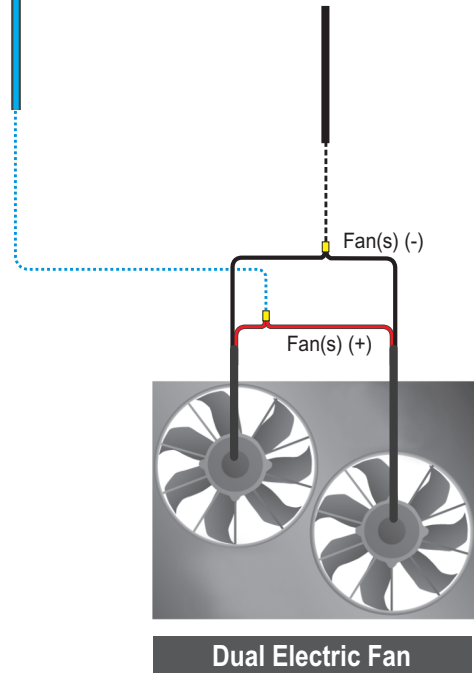

Derale Performance
PART # 16797

Customer Service
323-266-3850

ATTENTION

**If you have any
technical questions
about this controller
please contact
Derale Performance.**

Phone: (323) 266-3850

Email:

techsupport@usmotorworks.com